

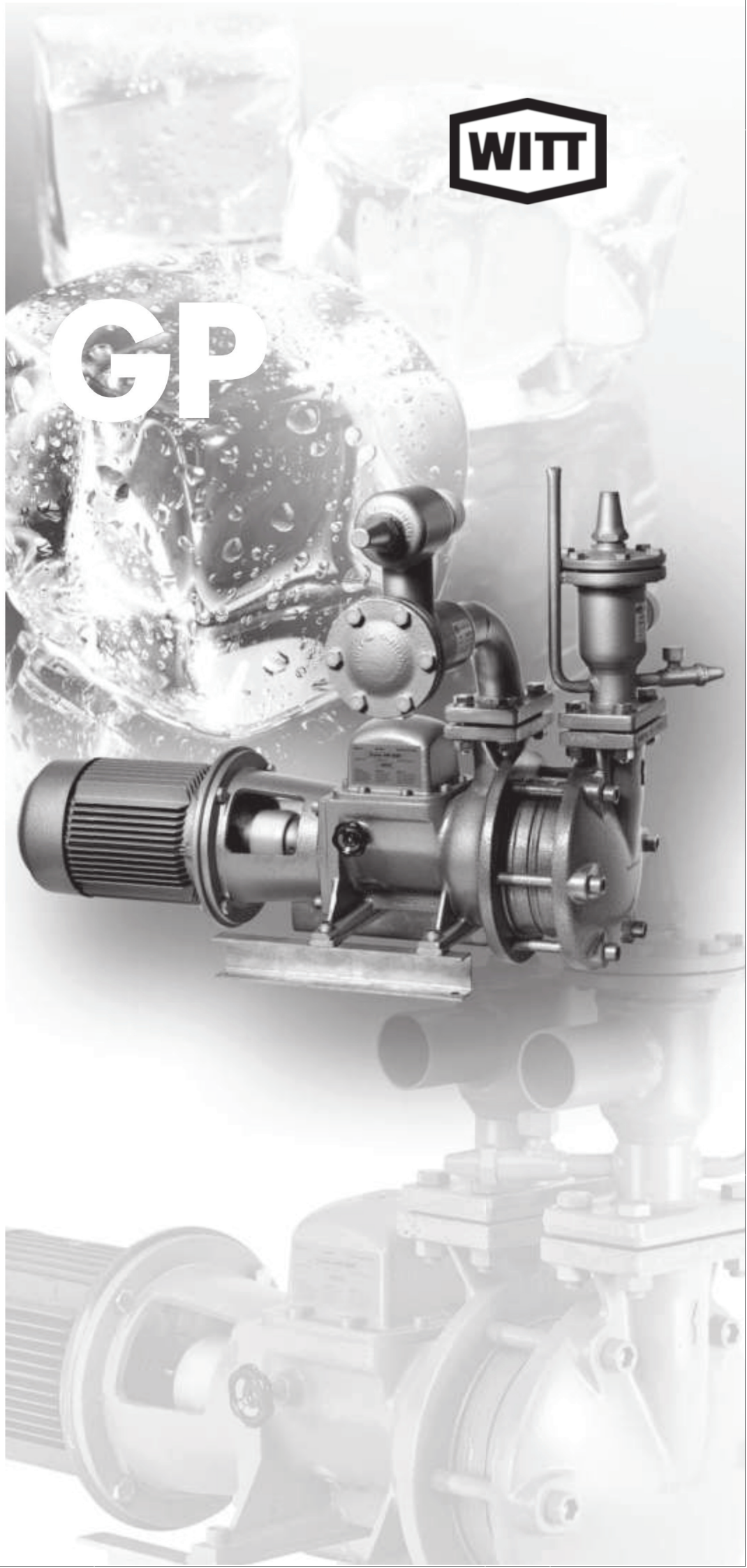

GP

**Open
refrigerant pumps**
*Installation and
operating instructions*

- GP 41**
- GP 42**
- GP 51**
- GP 51A**
- GP 52**
- GP 82**





1.3 SAFETY ADVICE

The pump is designed for use in industrial refrigeration systems using primary refrigerants.



It is very important that everybody responsible for the safe operation and maintenance of the plant reads this manual.



The coupling protection must be in place at all times! (see chapter 8.2.2)

If you have any problems please do not hesitate to call our service department, who will be glad to assist you.

Make sure the ground area around the pump is clear, e.g. no incoming electric power cables. If you cannot avoid such obstruction, they should be marked with two-coloured warning tape (warning sign).

Correctly retighten all screw connections after maintenance and repair work.

If you have to disassemble any safety devices for maintenance and repair make sure that upon completion of said work the re-assembly and correct functioning is checked.

When operating at low temperatures ($< 0^{\circ}\text{C}$) freeze bites can occur when the surface is touched. Therefore always wear appropriate protection clothing.

1.4 DISCLAIMER

Even when using the pump for the intended purpose it cannot be entirely excluded that a danger may remain during its working lifetime.

Translations have been made to the best of our knowledge. We are unable to accept any liability for errors in translation.

We reserve the right to change descriptions, graphs and technical information due to future development of the refrigerant pump.



4. TECHNICAL DATA

4.1 GENERAL INFORMATION

DESCRIPTION	GP 41	GP 42	GP 51	GP 51a	GP 52	GP 82
Volume refrigerant side [litr.]	1,75	1,85	4,10	4,10	5,25	7,72
Reservoir oil content [litr.]	1,70	1,70	2,00	2,00	2,00	2,00
Flange connection [DN]	40,00	40,00	50,00	50,00	50,00	50/80
Weight [kg] for						
Model 1	41,00	45,00	63,00	63,00	73,00	91,00
Model 2	48,00	52,00	75,00	75,00	92,00	110,00
Model 4	dependent	dependent	dependent	dependent	dependent	dependent

4.2 MOTOR DATA

4.2.1 Motor data for 50 Hz - 1.500 RPM

	Density [kg/dm ³]	Motor size	Power [kW]	Voltage [V]		Weight [kg]	Remark
				Δ	Y		
GP 41	< 0,7 (NH3)	80	0,55	220 - 240	380 - 420	10	Standard
	< 1,4		0,75			12	
	< 1,6	90S	1,1			14	
	< 1,8						
GP 42	< 0,7 (NH3)	90S	1,1	220 - 240	380 - 420	14	Standard
	< 1,4	90L	1,5			17	
	< 1,6						100L
	< 1,8						
GP 51	< 0,7 (NH3)	100L	3	220 - 240 380 - 420	380 - 420 660 - 725	28	Standard
	< 1,4	112M	4			40	
	< 1,6	132S	5,5			66	Motor adapter ring necessary
	< 1,8						
GP 51a	< 0,7 (NH3)	100L	2,2	220 - 240	380 - 420	17	Standard
	< 1,4	112M	4	220 - 240 380 - 420	380 - 420 660 - 725	40	
	< 1,6						
	< 1,8						
GP 52	< 0,7 (NH3)	132S	5,5	220 - 240 380 - 420	380 - 420 660 - 725	66	Standard
GP 82	< 0,7 (NH3)	132M	7,5	380 - 420	660 - 725	64	Standard

4.2.2 Motor data for 50 Hz - 1.000 RPM

	Density [kg/dm ³]	Motor size	Power [kW]	Voltage [V]		Weight [kg]	Remark		
				Δ	Y				
GP 41	< 0,7 (NH3)	80	0,37	220 - 240	380 - 420	9			
	< 1,4								
	< 1,6								
	< 1,8								
GP 42	< 0,7 (NH3)	80	0,37	220 - 240	380 - 420	9			
	< 1,4		0,55			11			
	< 1,6								
	< 1,8								
GP 51	< 0,7 (NH3)	100L	1,5	220 - 240	380 - 420	25			
	< 1,4	112M					2,2	38	
	< 1,6								
	< 1,8								
GP 51a	< 0,7 (NH3)	100L	1,5	220 - 240	380 - 420	26			
	< 1,4								
	< 1,6								
	< 1,8								
GP 52	< 0,7 (NH3)	100L	1,5	220 - 240	380 - 420	26			
	< 1,4	112M	2,2			38			
	< 1,6	132S	3	220 - 240	380 - 420	66	Motor adapter ring necessary		
	< 1,8	132M	4	380 - 420	660 - 725	82			

4.2.3 Motor data for 60 Hz - 1.800 RPM

	Density [kg/dm ³]	Motor size	Power [kW]	Voltage [V]		Weight [kg]	Remark
				Δ	Y		
GP 41	< 0,7 (NH3)	80	0,9	254 - 280	440 - 480	12	
	< 1,4	90S	1,3			14	
	< 1,6	90L	1,8			17	
	< 1,8						
GP 42	< 0,7 (NH3)	90L	1,8	254 - 280	440 - 480	17	
	< 1,4	100L	2,6			22	
	< 1,6						
GP 51	< 0,7 (NH3)	112M	4,8	254 - 280 460	440 - 480	40	
	< 1,4	132S	6,6	460	---	66	Motor adapter ring necessary
GP 51a	< 0,7 (NH3)	112M	4,8	254 - 280 460	440 - 480	40	
	< 1,4	132S	6,6	460	---	66	Motor adapter ring necessary
GP 82	< 0,7 (NH3)	132M	7,5	460	---	64	



4.2.4 Motor data for 60 Hz - 1.200 RPM

	Density [kg/dm ³]	Motor size	Power [kW]	Voltage [V]		Weight [kg]	Remark
				Δ	Y		
GP 41	< 0,7 (NH3)	80	0,44	254 - 280	440 - 480	9	
	< 1,4						
	< 1,6		0,66				
	< 1,8					11	
GP 42	< 0,7 (NH3)	80	0,66	254 - 280	440 - 480	11	
	< 1,4	90S	0,9			13	
	< 1,6					90L	1,3
	< 1,8						
GP 51	< 0,7 (NH3)	100L	1,8	254 - 280	440 - 480	25	
	< 1,4	112M	2,6			38	
	< 1,6						
	< 1,8						
GP 51a	< 0,7 (NH3)	100L	1,8	254 - 280	440 - 480	26	
	< 1,4	112M	2,6			38	
	< 1,6						
	< 1,8						
GP 52	< 0,7 (NH3)	112M	2,6	254 - 280	440 - 480	38	
	< 1,4	132S	3,6	254 - 280		66	Motor adapter ring necessary
	< 1,6	132M	4,8	460		82	
	< 1,8		6,6	460		---	

4.3 MATERIAS

Pump housing:	EN-GJS-400-18-LT	Motor flange:	EN GJS-400-15
Coupling:	Stahl	Coupling bush:	Kunststoff
Coupling protection:	PVC Rohr transparent	Ball bearings:	Stahl
Shaft:	C 35	Shaft seal:	PTFE
Impellers:	EN GJS-400-15	Main bolts	8.8
Counter flanges:	P355NH	Bolts for counter flanges:	8.8
Gaskets:	Centellen NP	Reservoir oil:	MR 520
Painting system	W 9.1 + W 9.2 *		

* W9.1 + W9.2 = 2k epoxyd finish according DIN ISO 12944/5, RAL 7001

4.4 PRESSURE RANGE

Design pressure pump housing [bar]	16
Test pressure (air under water) [bar]	17,6
Permitted operating pressure range [bar]	16 (+50 / -10°C) 8 (-10 / -60°C)

4.5.2 Dimensions GP 51 / GP 51a / GP 52

All dimensions in mm (inch)

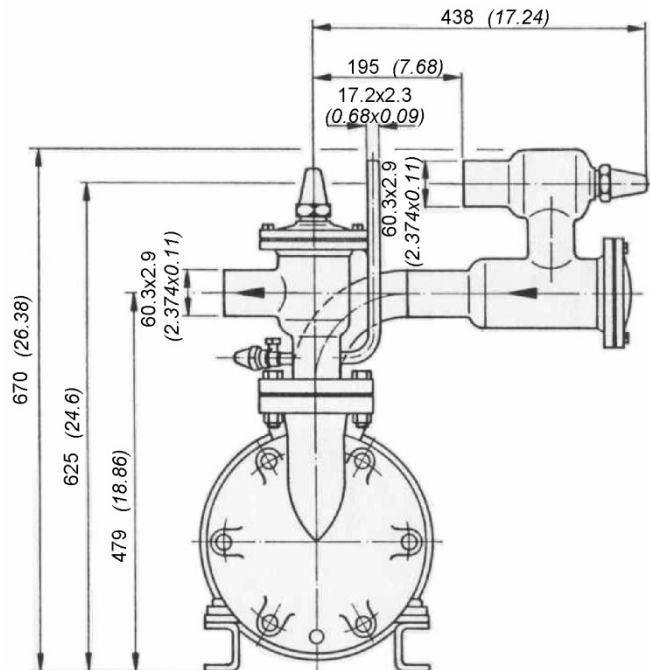
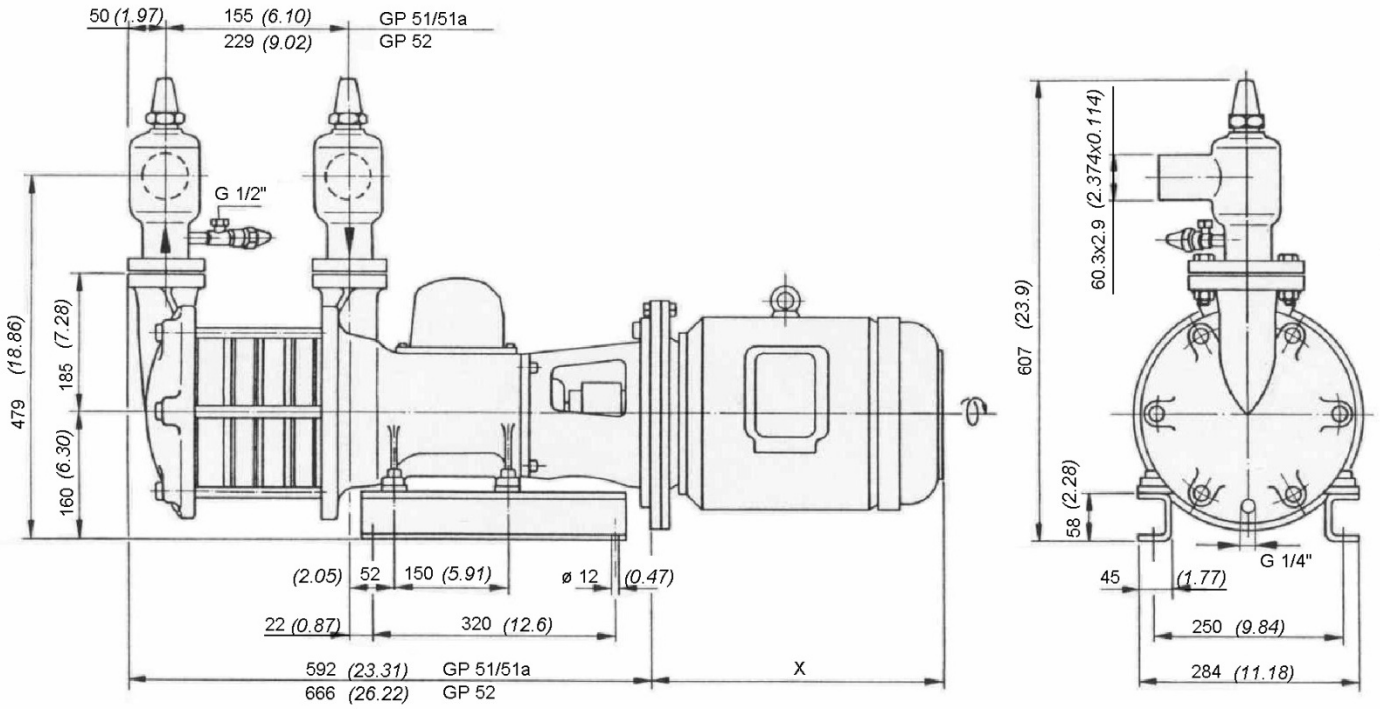

4.9 DESCRIPTION OF OPERATION

From the surge drum refrigerant liquid flows into the suction chamber of the pump. A conical filter is positioned in the suction connection. A special design of the suction chamber reduces the inlet friction. The fluid pressure is increased by passing through one or two stage impellers and intermediate piece(s).

Due to the lateral channels in the intermediate pieces the pump can deliver a gas/liquid mixture without surging or reversing the flow.

The special double shaft seal with associated oil reservoir in the between ensures that no refrigerant will escape outside the system.

During standstill any gas that evaporates must be able to leave the pump and vent to the surge drum. If the pump can be isolated on the delivery side or if a return valve is mounted, a purge line with a diameter of 10 mm (0.4") must be installed between delivery flange and stop valve and connected to the wet suction return line.

The WITT stop/return valve ERA is provided with a purge connection pipe DN 10 and a hand regulating valve EE6, supplied loose. The EE6 should be fitted so that any gas may be purged to the surge drum. The valve should be left ½ - ¼-turn open depending on the differential pressure (see also fig. 6).

4.10 PERFORMANCE CHARACTERISTIC TABLE

1450 1/min (RPM)

LIQUID HEAD [m]	PRESSURE DIFFERENCE [bar]				VOLUME FLOW [m³/h]					
	NH ₃		R 22		GP 41	GP 42	GP 51A	GP 51	GP 52	GP 82
	EVAPORATING TEMPERATURE t ₀									
	+40°C	-40°C	+40°C	-40°C						
2	0,11	0,14	0,22	0,28	3,4	3,6	10,2	16,8	16,8	24
4	0,23	0,27	0,44	0,55	3,2	3,4	10	16,5	16,5	23,5
6	0,34	0,41	0,67	0,83	2,9	3,3	9,7	16,3	16,3	23
8	0,45	0,54	0,89	1,13	2,7	3,1	9,4	16,1	16,2	22,4
10	0,57	0,68	1,11	1,38	2,6	3	9	15,7	16,1	21,8
15	0,85	1,02	1,67	2,08	2,2	2,6	8,3	14,2	16	20,3
20	1,14	1,35	2,22	2,77	1,8	2,4	7,4	12,3	15,8	19
25	1,42	1,69	2,78	3,46	1,4	2,1	6,3	9,8	15,1	17,8
30	1,7	2,03	3,33	4,15	-	1,9	5,5	7	14,2	16,6
35	1,99	2,37	3,89	4,84	-	1,6	4,5	3,6	13,5	15,5
40	2,27	2,71	4,45	5,54	-	1,3	-	0	12,5	14,3
45	2,56	3,05	5	6,23	-	1,1	-	-	11,1	13
50	2,84	3,38	5,56	6,92	-	0,8	-	-	10,4	11,6
55	3,12	3,72	6,11	7,61	-	-	-	-	9,3	10
60	3,41	4,06	6,67	8,31	-	-	-	-	8	8,4
65	3,69	4,4	7,22	9	-	-	-	-	6,5	-
70	3,98	4,74	7,78	9,69	-	-	-	-	5	-

1 m = 3.281 ft | 1 bar = 14.504 PSI | 1 m³/h = 4.403 gal/min

Shut off valves in the suction line shall be sized generously and without reducers to enable degassing. Installation of full-bore ball valves are recommended. Straight through valves must be installed with stem in horizontal position; ball valves should not have a reduced bore on the pump side connection.

Until now we have not recommend filters in the liquid downleg as these create additional pressure loss. However, positive experience has proven that the use of filters in systems with high levels of contamination (i.e. due to installation of non-shot blasted pipes and vessels) is better than contamination of the pump.

Filters with a mesh of 500 µm (e.g. Parker T5F-SS, AWP-SS, RFF FA or Danfoss FIA) should be installed in systems with a potential for contamination.



Upmost care should be taken to clean the filters as often as possible during the first weeks of operation, until they remain clean.

Since external filters have a larger filter surface and can be cleaned more easily, we recommend you keep these in place and remove the conical filter in the pump inlet to avoid two filters causing excessive pressure drop. A regular check (1 – 2 per year) should be included in the maintenance routine.



To be sure the pump will operate even at a low-pressure difference resulting in maximum capacity, the diameter of the downleg to the pump must be executed as mentioned in the table below as a minimum!

Required diameter of the downleg to the pumps

	GP 41	GP 42	GP 51 / GP 51a	GP 52	GP 82
50 Hz	DN 80	DN 80	DN 100	DN 150	DN 150
60 Hz	3"	3"	4"	6"	6"



Under no circumstances should the maximum velocity in the downleg exceed 0.3 m/s (1 ft/s)!

The conical suction filter supplied with the pump must be installed at all times to protect the pump from foreign material contamination!

6.5.1 Safeguarding against too high pressure



Operating refrigerant pumps against too high pressure (e.g. against partially or fully closed throttled condition) is not allowed and will damage the refrigerant pump!

A **by-pass valve** (adjustable) has proven good practice to safeguard the pump against too high pressure.

To set the by-pass valve select the pressure difference across the pump according table 1 for the following de-livery head. (take into account the pressure losses in the pipework to the by-pass valve)

	960 RPM	1150 RPM	1450 RPM	1740 RPM
GP 41	11 m	16 m	25 m	36 m
GP 42	20 m	30 m	48 m	70 m
GP 51	13 m	19 m	31 m	47 m
GP 51a	16 m	23 m	37 m	50 m
GP 52	26 m	40 m	65 m	-
GP 82	-	-	55 m	85 m



A diameter of DN20 has been proven for the by-pass valve.

6.5.2 Dry-run protection

If a **minimum level cut out switch** is mounted on the separator, it shall be used to switch the pump off in case of a lack of refrigerant (dry run protection).

6.5.3 Pressure differential switch

A pressure differential switch - with time delay during start up - shall be used when there is insufficient discharge pressure.

The delay should be set at approx. 30 s, which means if the pump was not able to build up pressure (e.g. 0,3 – 0,5 bar) within 30 s, the pump will be stopped

This procedure can be repeated a maximum of four times. Then a malfunction message should be submitted and the pump switched off. After that a restart should only be made after investigation of the cause of failure and acknowledging the fault indicator.

The pressure differential switch does not protect the pump against too high pressure running (dead heading)!

6.5.4 Flow switch

A **flow switch** must be installed, when a bypass valve is not fitted in the refrigerant circuit. It is known when the bypass valve is not fitted, the pump is capable of producing a differential pressure without volume flow and has not been stopped by the differential pressure switch. The flow switch control in the pump discharge shall stop the flow as the flow drops below 0,2 m/s.

See also WITT information sheet W 4652-0.01